

Third Solar Panel

Installation Manual

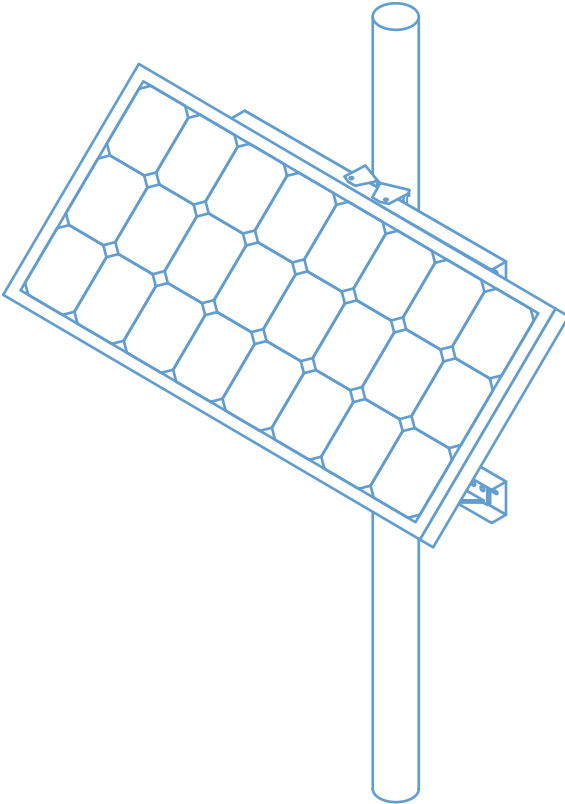

Assembled Unit

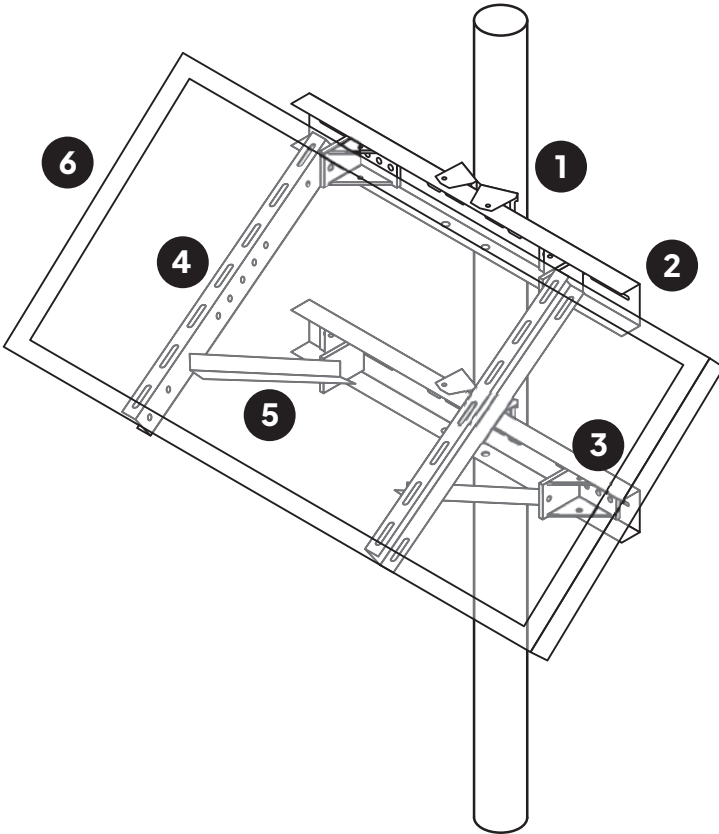

- 1. Mount bracket
- 2. Saddle bracket
- 3. L bracket
- 4. Side rail
- 5. Tilt leg
- 6. Solar panel

Unlimited Support

If you have any questions or issues with your TrueLook system, please don't hesitate to contact our Customer Support team.

Phone 833-878-3566 (Option 2)

Email support@truelook.com

You can also submit a support request online at:

support.truelook.com/contact-support

Online Resources

Visit truelook.com/install to access:

- ✔ A guide to administrative settings and time-lapse setup
- ✔ Video demonstrations of installation procedures
- ✔ And more!

For Terms & Conditions, as well as Warranty information, visit: truelook.com/terms-conditions.

Hardware Packing List

Solar Panel [1x]

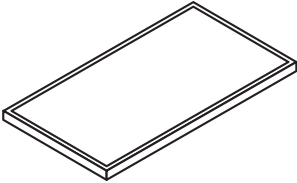

Positive Fuse Connectors [3x]

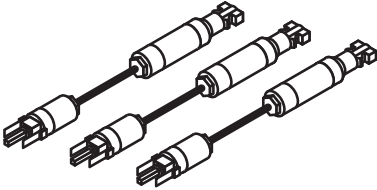

3-to-1 Connectors [2x]

Only supplied for solar models that do not already utilize this connector type.

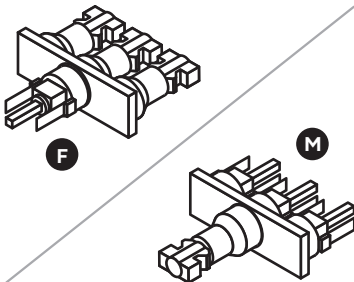

20' Panels to Battery

Enclosure Cable

Supplied with select solar models.

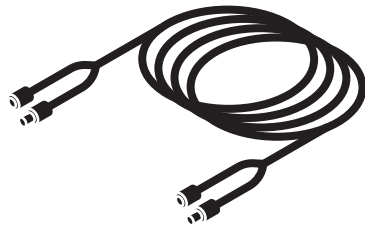

Getting Started

Mounting Hardware

Mount Brackets [2x]

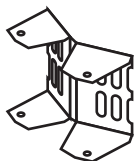

Steel Straps [4x]

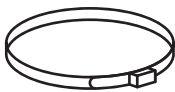

L Brackets [4x]

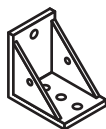

Saddle Brackets [2x]

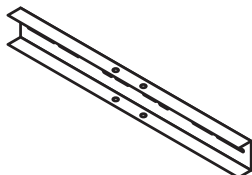

Side Rails [2x]

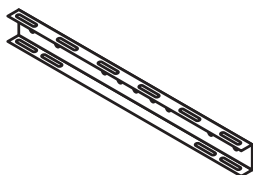

Tilt Legs [2x]

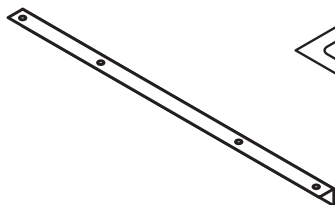

Anti-Seize Packet [1x]

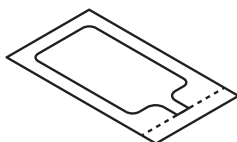

Assorted Hardware

5/16" bolts



5/16" nuts



1/4" bolts



1/4" nuts



Preparing for Installation

Solar Panel Positioning

Warning: Failure to observe all following requirements may result in system downtime. Units self-recover automatically once panels receive sufficient sunlight.

Step 1 Ensure panels will face **due south**.

The chosen mounting location should allow the panels to face the equator (**directly south**) in order to capture adequate sunlight and properly charge.

Step 2 Determine your panels' angle.

Refer to the chart on the following page to find the proper angle for your solar panels based on your state.

Step 3 Ensure panels remain unobstructed.

Panels must receive direct sunlight throughout the day. Do not let trees, equipment, structures, or anything else block the sun.

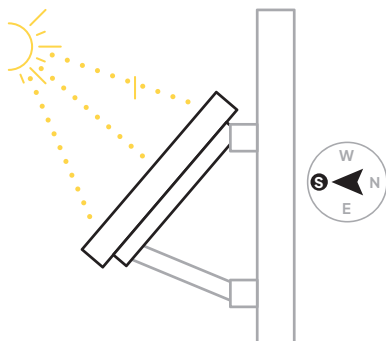

Panel Angles by State

Alabama	45°	New Hampshire	65°
Alaska	80°	New Jersey	65°
Arizona	45°	New Mexico	45°
Arkansas	60°	New York	65°
California	45°	North Carolina	60°
Colorado	55°	North Dakota	70°
Connecticut	60°	Ohio	60°
Delaware	65°	Oklahoma	50°
District of Col.	60°	Oregon	65°
Florida	45°	Pennsylvania	65°
Georgia	55°	Rhode Island	65°
Hawaii	40°	South Carolina	55°
Idaho	65°	South Dakota	65°
Illinois	65°	Tennessee	60°
Indiana	65°	Texas	45°
Iowa	65°	Utah	65°
Kansas	65°	Vermont	65°
Kentucky	60°	Virginia	60°
Louisiana	45°	Washington	65°
Maine	65°	West Virginia	60°
Maryland	60°	Wisconsin	65°
Massachusetts	65°	Wyoming	65°
Michigan	65°		
Minnesota	65°		
Mississippi	45°		
Missouri	60°		
Montana	70°		
Nebraska	65°		
Nevada	65°		

Determine Mounting Hardware

Pole Mounting

Your panel mounting kit includes steel straps for pole mounting. For jobsites that experience extreme wind conditions, we suggest using one of the following hardware options in their place:

- ✔ U bolts
- ✔ Lag bolts
- ✔ Through bolts

When using any of these alternatives, discard the mount brackets and place chosen bolts directly into the saddle brackets.

Wall Mounting

Your panel mounting kit **does not include** hardware for wall mounting. Choose appropriate mounting hardware for your surface.

Mounting Hardware

Pole Mounting

Warning: Wear protective work gloves throughout installation process. Solar panels and other hardware pieces have sharp edges.

Step 1 Secure one mount bracket to pole at maximum desired height using two steel straps. Tighten each strap around pole using a drill with a 5/16" hex head driver bit (not included) and trim steel straps to desired length using tin snips (not included).

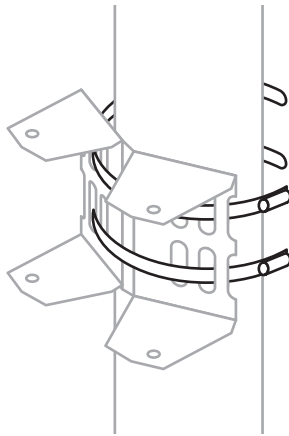

Installation

Step 2 Secure one saddle bracket to mount bracket using 5/16" hardware.

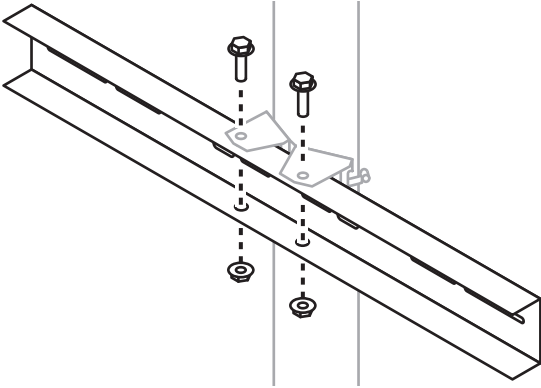

Step 3 Secure lower mount bracket to pole using previous method. Do not fully tighten bracket to pole.

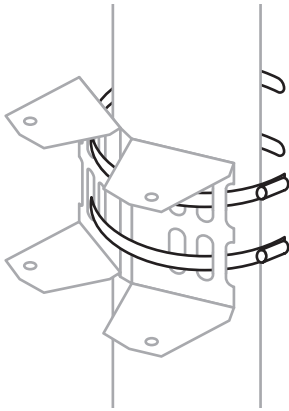

Installation

Step 4 Secure lower saddle bracket to mount bracket using 5/16" hardware.

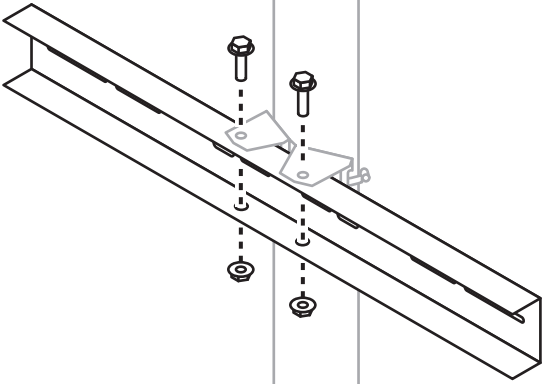

Step 5 Adjust lower hardware so saddle brackets are necessary distance apart for needed angle degree (see chart), then fully tighten lower mount bracket to pole.

Angle	Single Panel Rail (28 in)
30°	9.5 in
45°	20 in
60°	27 in

A perspective diagram showing the same rail and pole assembly as in Step 4. The rail is now tilted at an angle. Two vertical dashed lines with arrows at both ends indicate the distance between the saddle brackets on the rail, which is used to determine the required angle.

Installation

Step 6 Lay side rails on solar panel holes to estimate upper L bracket spacing. Measure between inside of rails for accuracy.

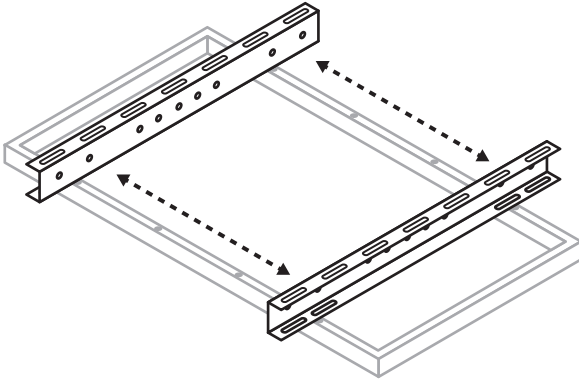

Step 7 Attach L brackets to upper and lower saddle brackets using 5/16" hardware. Lower L brackets face outward, and upper L brackets face inward.

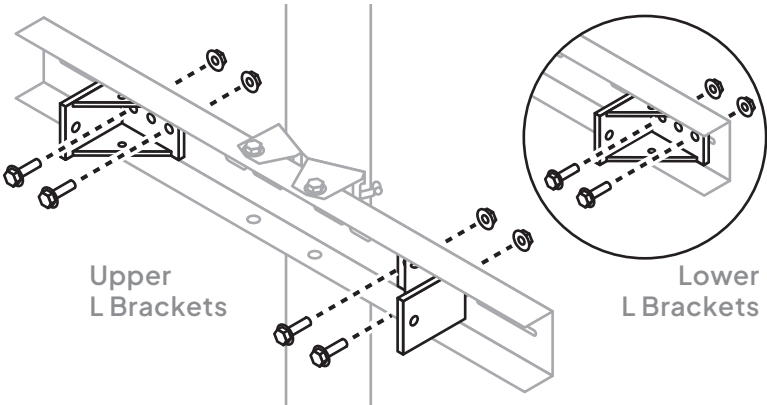

Installation

Step 8 Secure side rails to exterior of L brackets on upper saddle bracket using 5/16" hardware.

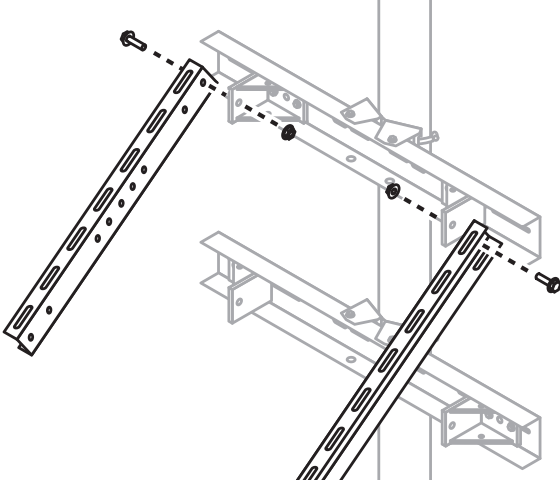

Step 9 Attach tilt legs to interior of L brackets on lower saddle bracket using 5/16" hardware.

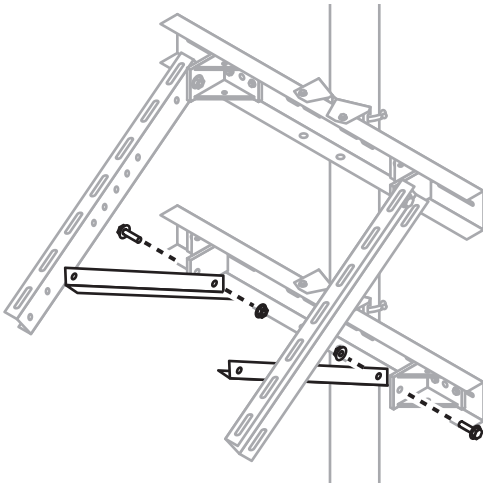

Installation

Step 10 Secure tilt legs to side rails using 5/16" hardware.

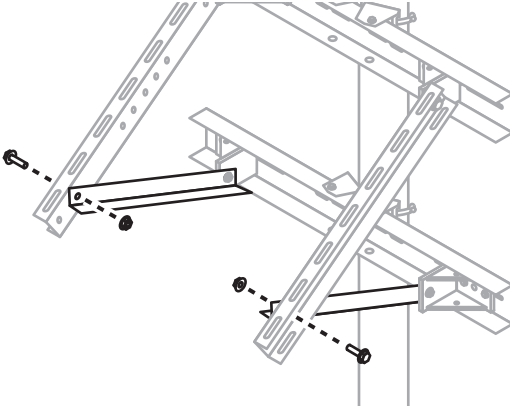

Step 11 Check all bolts are securely tightened.

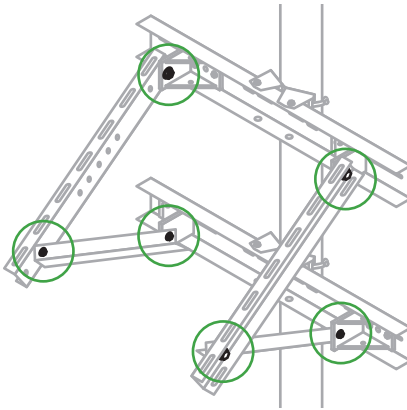

Step 12 Using disposable gloves, carefully apply anti-seize to all nuts and bolts.

Installation

Wall Mounting

Warning: Wear protective work gloves throughout installation process. Solar panels and other hardware pieces have sharp edges.

Step 1 Set aside mount brackets, as these aren't needed for wall mounting.

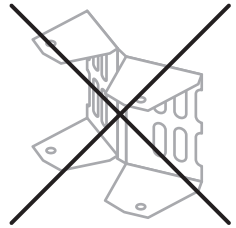

Step 2 Lay side rails on solar panel holes to estimate upper L bracket spacing. Measure between inside of rails for accuracy.

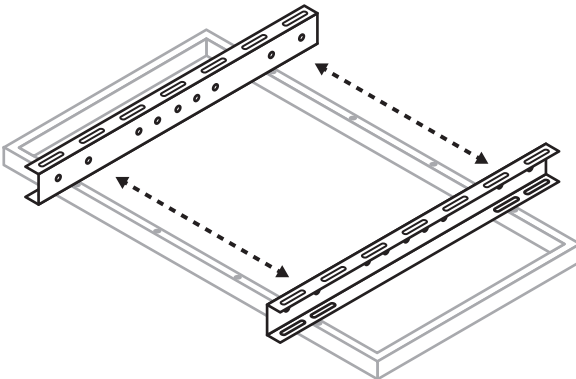

Installation

Step 3 Attach L brackets to upper and lower saddle brackets using 5/16" hardware. Lower L brackets face outward, and upper L brackets face inward.

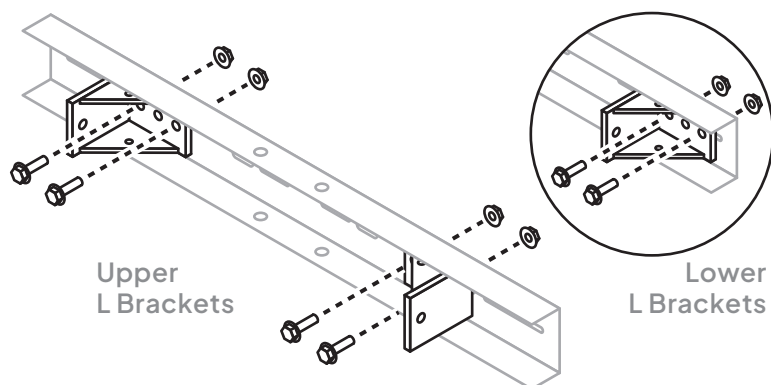

Step 4 Using appropriate mounting hardware for your surface, secure upper saddle bracket directly to wall at maximum desired height.

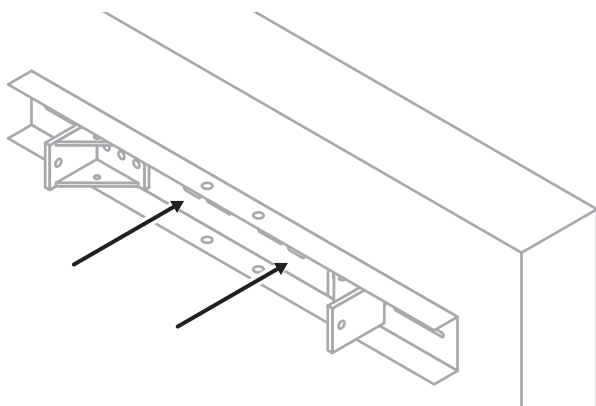

Installation

Step 5 Measure necessary distance downward for needed angle degree (see chart), then secure lower saddle bracket directly to wall using appropriate mounting hardware for your surface.

Angle	Single Panel Rail (28 in)
30°	9.5 in
45°	20 in
60°	27 in

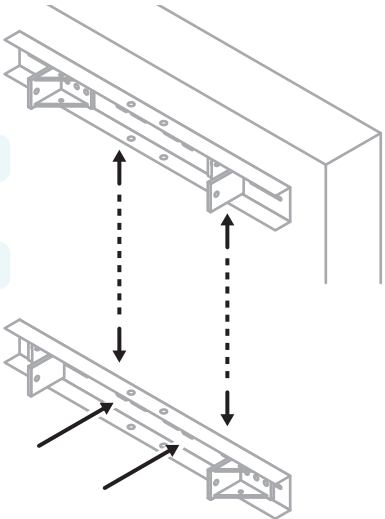

To complete assembly, follow pole mounting steps 8–12.

Solar Panel

Step 1 Secure solar panel to side rails using 1/4" hardware.

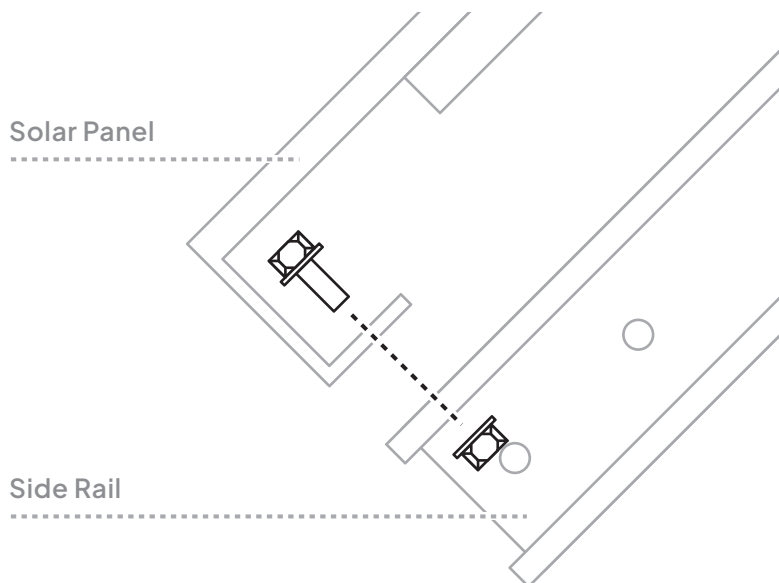

Step 2 Using disposable gloves, carefully apply anti-seize to nuts and bolts.

Connecting to System

Systems without 3-to-1 Connectors

You should not need to force connectors together.

Step 1 Disconnect cables that connect original two solar panels to battery enclosure.

Step 2 Plug male connector end coming from original two solar panels into open slot on forked end of male 3-to-1 connector.

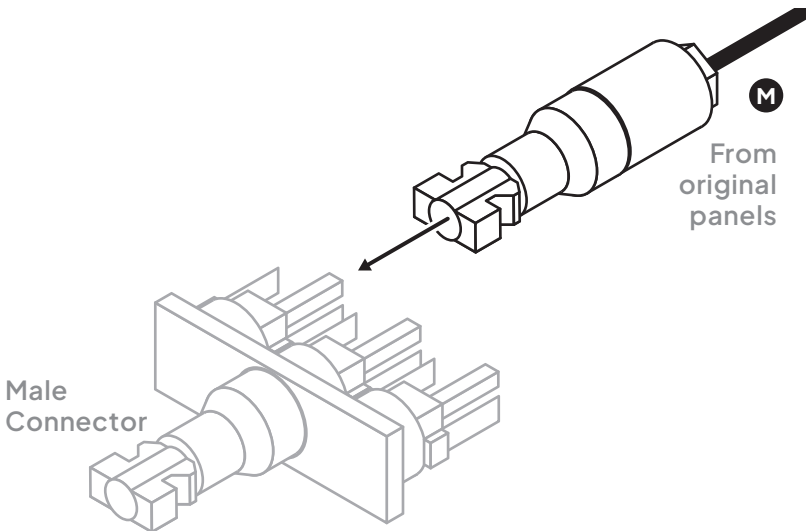

Connecting

Step 3 Plug male connector end coming from additional solar panel into open slot on forked end of male 3-to-1 connector. One slot on male 3-to-1 connector will remain unused.

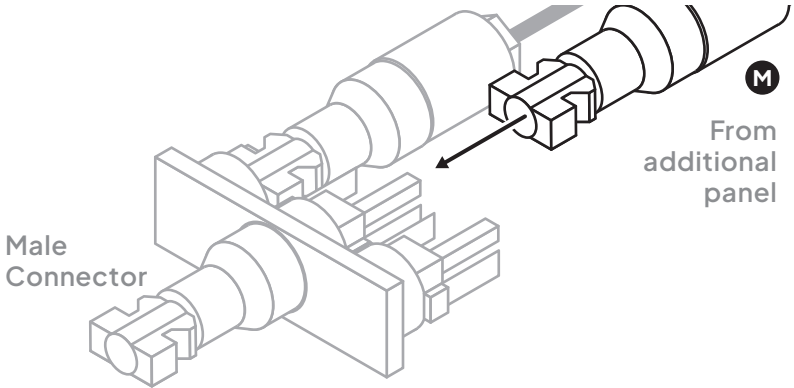

Step 4 Plug two positive fuse connectors into open slots on forked end of female 3-to-1 connector. One positive fuse connector will remain unused.

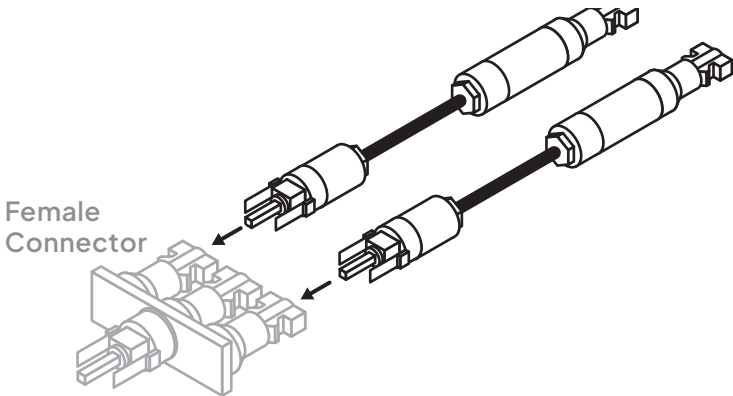

Connecting

Step 5 Plug female connector end coming from original two solar panels into a positive fuse connector.

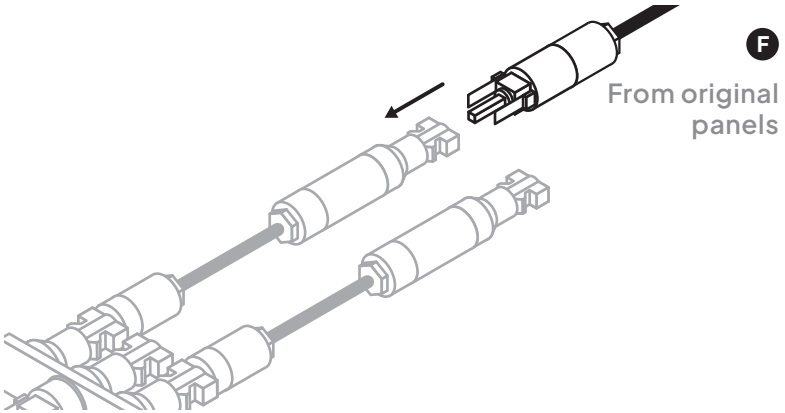

Step 6 Plug female connector end coming from additional solar panel into other positive fuse connector. One slot on female 3-to-1 connector will remain unused.

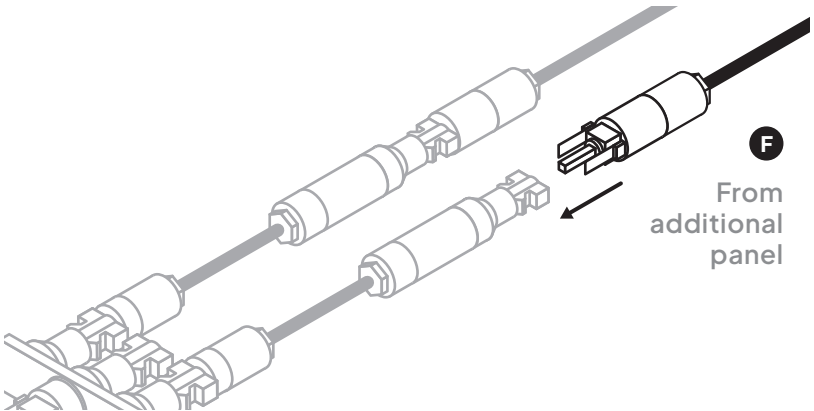

Connecting

Step 7 Connect male and female connector ends of 20' cable to singular ends of their respective 3-to-1 connectors.

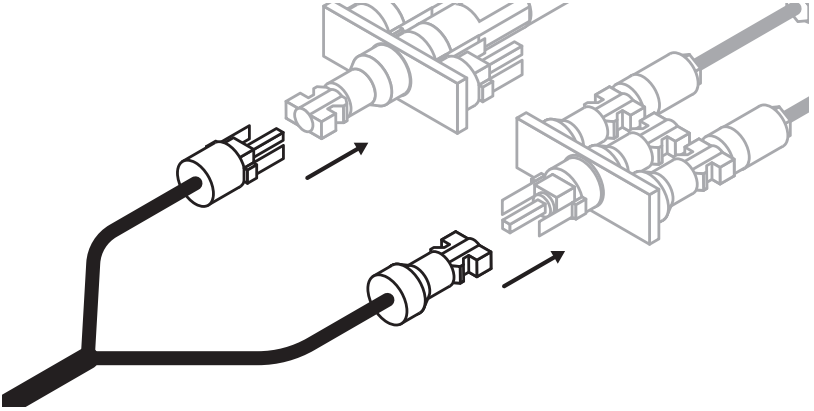

Step 8 Connect male and female connector ends of 20' cable to respective connectors coming from battery enclosure.

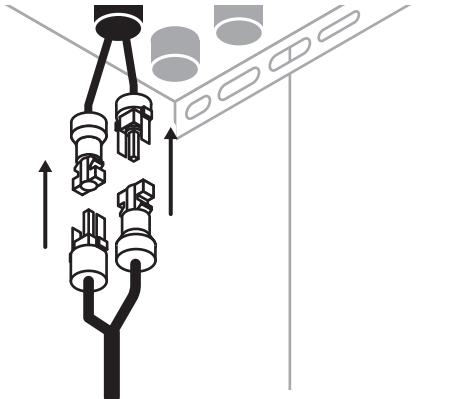

Connecting

Step 9 Check ProStar controller inside battery enclosure to verify power.

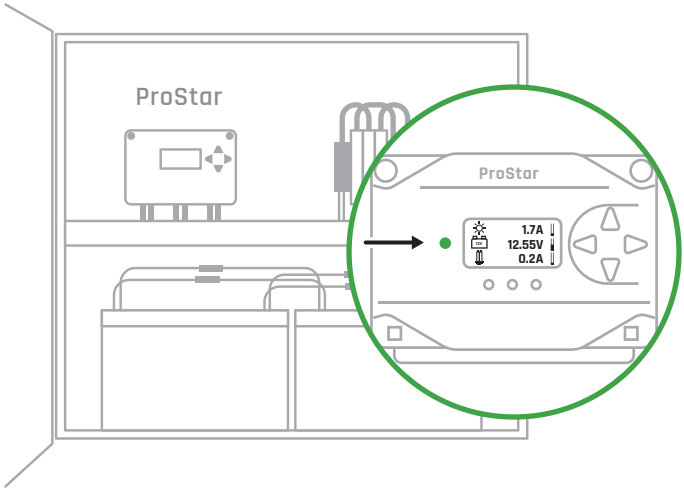

Connecting to System

Systems with 3-to-1 Connectors

You should not need to force connectors together.

Step 1 Detach connectors from single side of male and female 3-to-1 connectors to disconnect original two solar panels from battery enclosure.

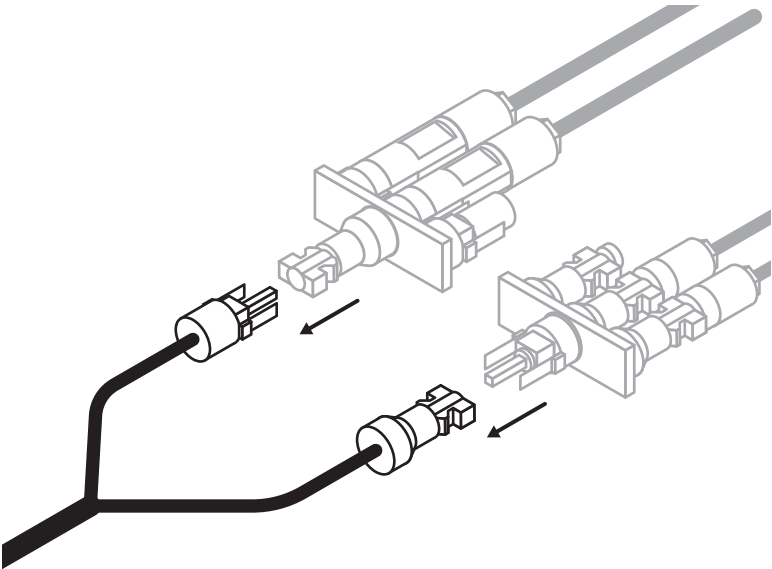

Connecting

Step 2 Remove all connectors from female 3-to-1 connector using needle nose pliers (not included) to depress side unlocking buttons.

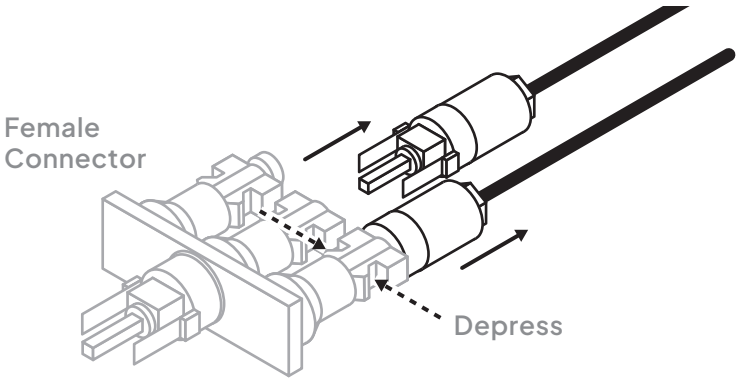

Step 3 Remove rubber cap from third port on female 3-to-1 connector.

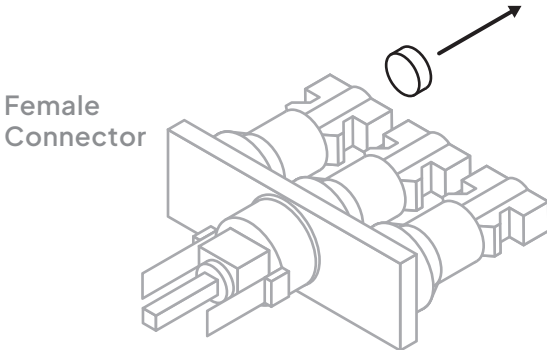

Connecting

Step 4 Plug all positive fuse connectors into female 3-to-1 connector.

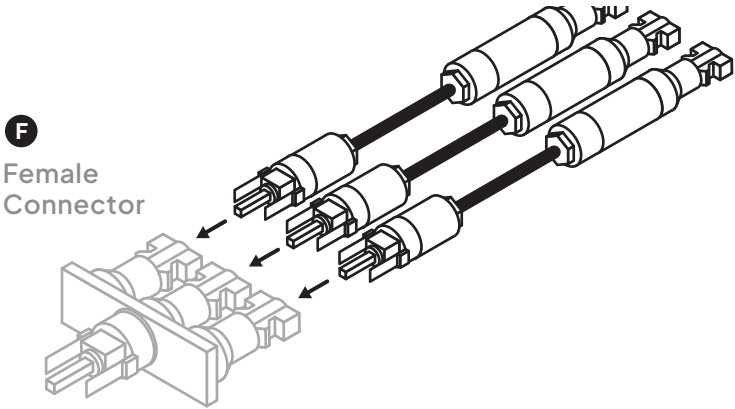

Step 5 Plug female connector ends coming from two original panels and additional panel into positive fuse connector ports.

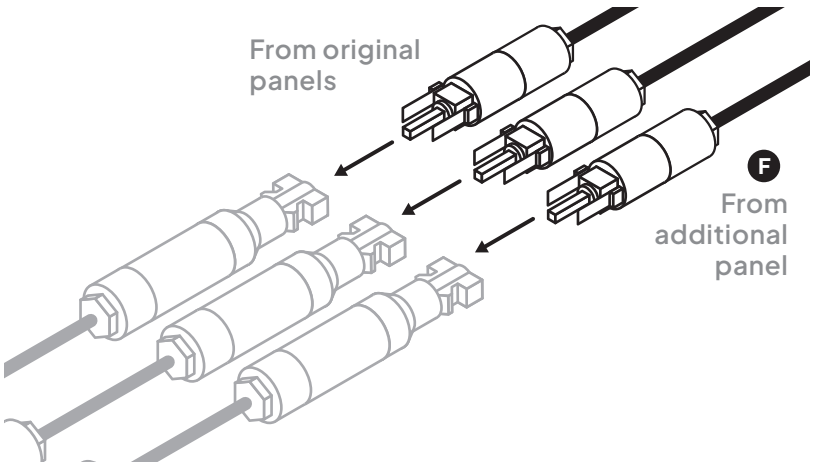

Connecting

Step 6 Remove rubber cap from third port on male 3-to-1 connector.

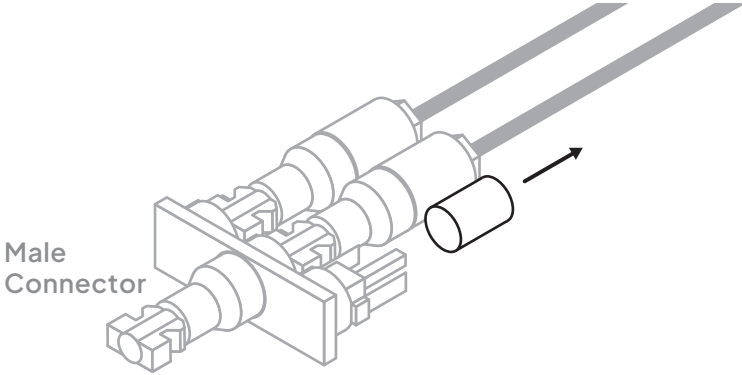

Step 7 Plug male connector end coming from additional panel into male 3-to-1 connector.

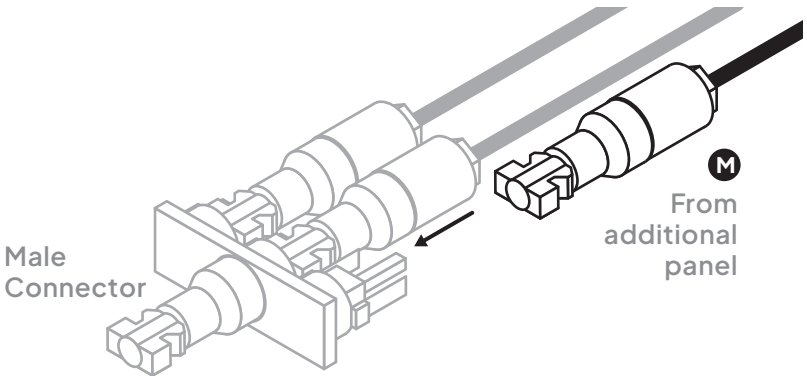

Connecting

Step 8 Reattach connectors coming from battery enclosure to single side of their respective 3-to-1 connectors to reconnect panels.

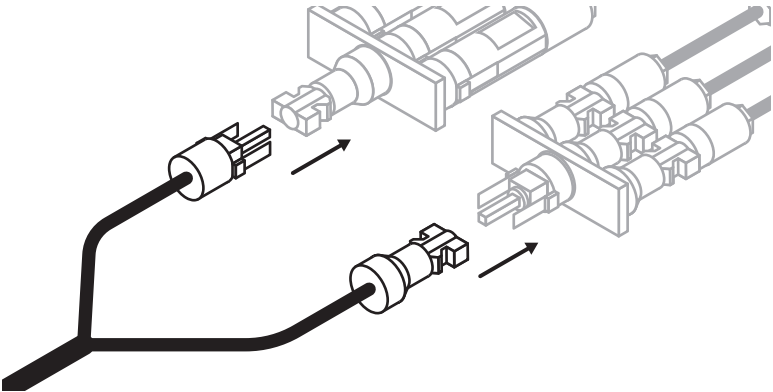

Step 9 Check ProStar controller inside battery enclosure to verify power.

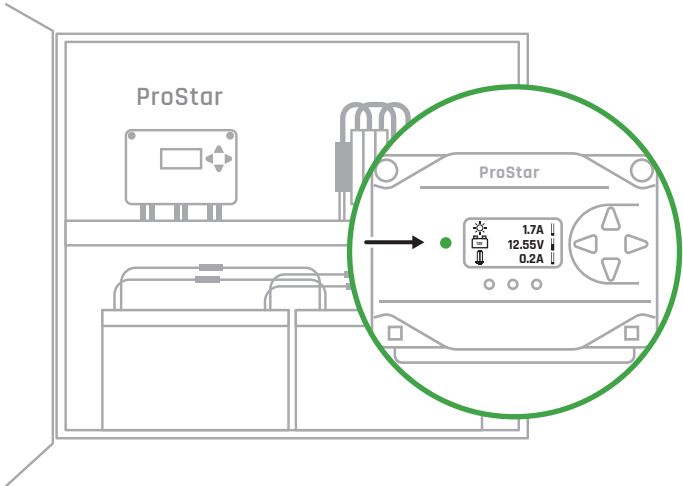

Troubleshooting

If something seems wrong with the system, it may be necessary to troubleshoot.

Cautions:

- Troubleshooting should be attempted by qualified personnel only.
- A battery can cause serious damage if shorted.
- Do not disassemble the ProStar from its case. There are no user serviceable parts inside the ProStar.

Camera Not Operating Properly

1. Check that the load breaker is turned on.
2. Check that the camera cable connectors are securely fastened.
3. If the ProStar internal temperature is above 80°C/176°F, the load will be disconnected, and all LEDs will be flashing in sequence. Check that nothing is obstructing the vents at the top of the case to ensure clear airflow around the ProStar.

Battery Is Not Charging

1. Check that all wire connections in the system are correct and tight.

If your system is still not functioning properly, please contact TrueLook Support for further assistance.

Maintenance Tips

- ✔ Do not allow smoking or open flames near the battery enclosure.
- ✔ If a battery has been unused for a long time, charge it externally with a battery charger prior to using it again for maximum efficiency.
- ✔ Solar panels are designed to quickly melt snow on their own. If there is a more urgent need to remove snow, gently use a soft brush. Using too much force may scratch or damage the panels.
- ✔ If the solar panels need cleaning, use only water and a microfiber cloth.
- ✔ Do not store any system components on the ground to avoid the intrusion of water or dirt.

Battery Replacement

We recommend the **Duracell Ultra Platinum AGM BCI Group 31M Deep Cycle Marine & RV Battery** as a replacement.

If you are unable to find this specific battery, the battery should meet the following specifications:

Product Category: Marine/RV	Capacity: 105AH
Voltage: 12	Capacity 20hr: 105AH
Format: BCI Group 31M	Cranking Amps: 1000
Chemistry: Lead Acid	Cold Cranking Amps: 800
Lead Acid Type: Deep Cycle, Dual Purpose (Starting/Cycling)	Marine Cranking Amps: 1000
Lead Acid Design: AGM	Terminal Type: DT, SAE/M8 Stud, SAE/M8 Threaded Post, WNT

Support Review

Did you know that our support team offers a free installation review?

Once you're done, simply snap a few pictures and email them to support@truelook.com. If we notice anything that we can help with, we'll reach out. This will also help our support team quickly view your setup if you run into equipment issues at any point in the future.

The Email

For the most efficient response from our team, include the following in your email:

1. Company name
2. Project name
3. Contact person for installation issues
4. The following photographs:
 - A. Your whole TrueLook solution: the camera, what it's mounted to, and any accessories
 - B. Close-ups of mounting
 - C. Close-ups of connections
 - D. Inside of battery enclosure